

Environment	Indoors and outdoors
Drive system	Screw-driven
Rated load	Up to 1000 kg / 8 persons
Speed	0.15 m/sec (9 m/min)
Travel height	Up to 15 metres
Landings	Up to 6
Platform dimensions (A/C x B/D, mm)	1400 X 2470
PIT	130 mm
Shaft dimensions (A/C x B/D, mm)	1850 X 2580
<small>*available custom dimensions</small>	
Door clearance (width x height, mm)	1290 X 2000
<small>*available other dimensions</small>	
Door configuration	Right or left swing door swing door up to 2 doors per landing Automatic double swing door
Shaft walls	Multi-layered sandwich panels or laminated glass panels (30 mm). Aluminum profile
Standard colors	RAL 9006 (light grey aluminum) RAL 9010 SPECIAL PRICE RAL 9005 SPECIAL PRICE
<small>*any RAL color available as option</small>	
Soft start/stop	As a standard
Power supply	380 V, 3 phase, 50 Hz
Motor	3 kW
Noise level	Less than 70 dB
Control system	Modern digital control system with LCD display
Technical safety equipment	Safety edge around the platform, emergency STOP buttons, electronic speed control, overload detector, opening control of doors and locks, electronic control of motor performance

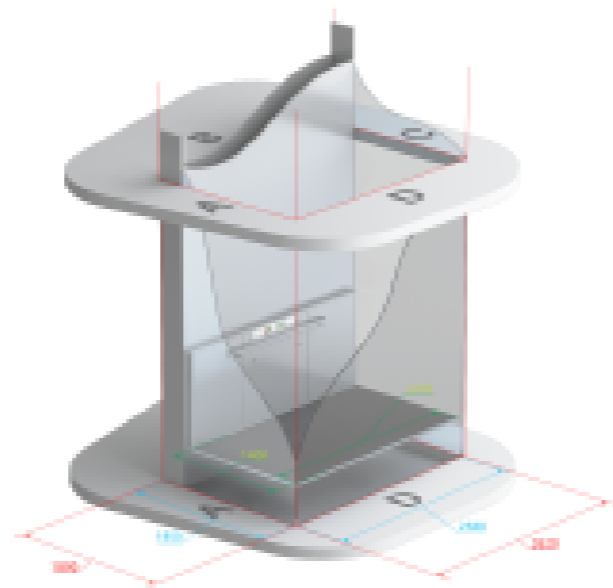

Certificate issued on the following requirements:
Machinery directive 2006/42/EC
EN 81-41:2010, EN 81-20:2020, EN 81-58:2022

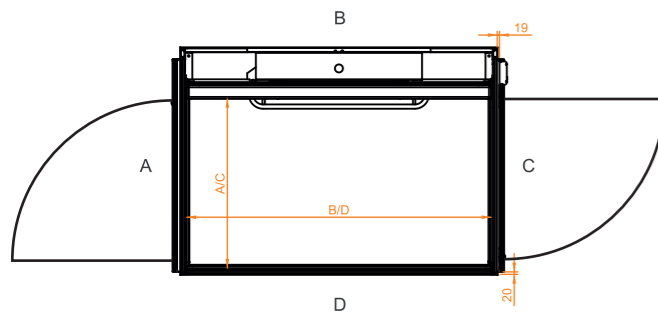

X



VB1000

Heavy lifting Platform lift



Exclusive partner



Witrac Elevator Sdn. Bhd.
Penang HQ & Showroom
No.1, Lorong Perusahaan Ringan Juru 1,
Kawasan Perusahaan Ringan Juru,
14100 Simpang Ampat,
Penang, Malaysia
HQ: 604-5057537
General Hotline: 1300-88-6537
Email: info@witrac.com.my

MADE IN EU

VB1000

The Heavy-Duty Platform Lift for All Your Lifting Needs

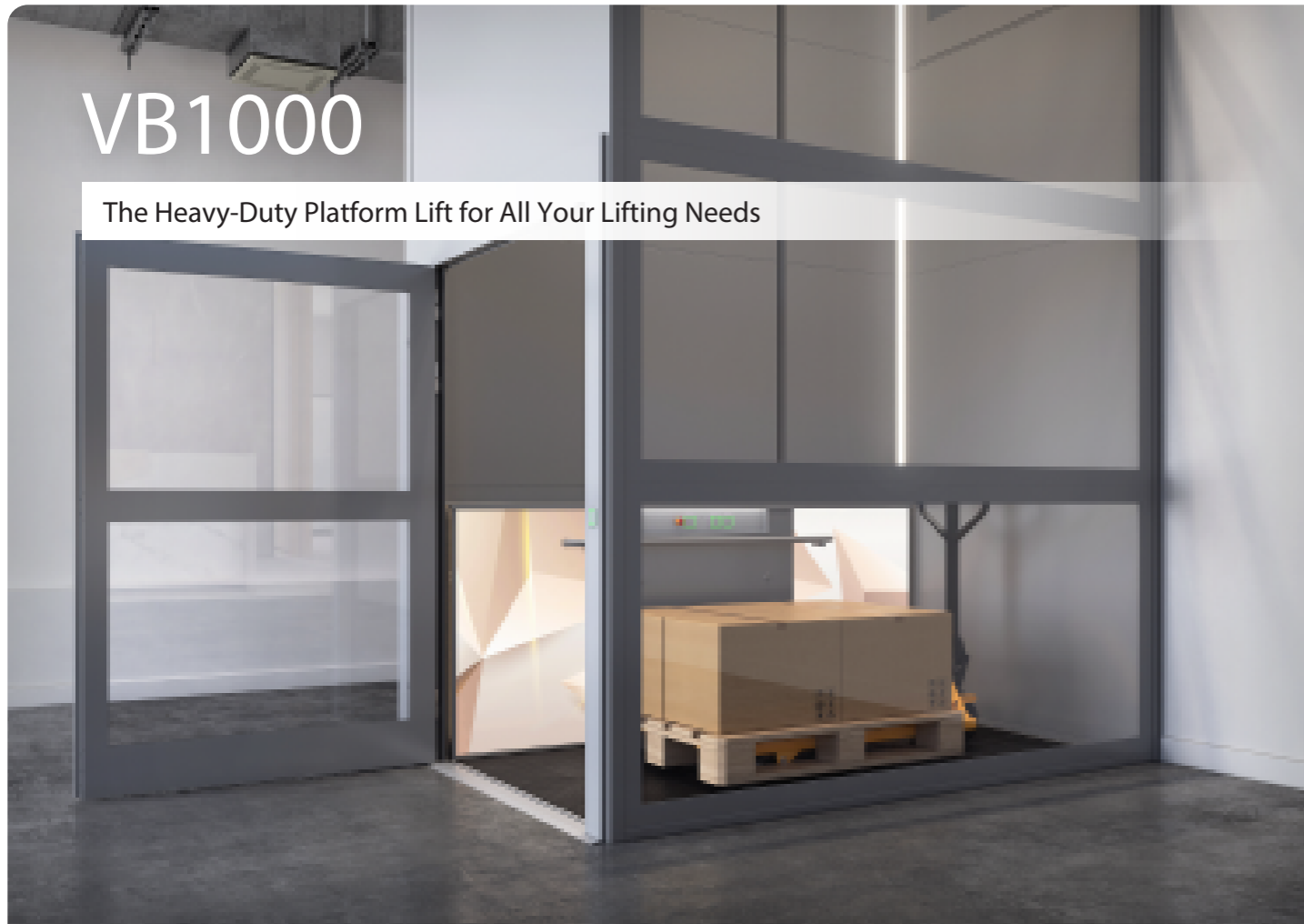

The VB1000 is ideal for those who require a heavy-duty lift solution.

Here are just a few of the benefits of the VB1000:

- High weight capacity: The VB1000 boasts a weight capacity that surpasses standard home elevators, making it perfect for transporting heavy items.
- Smooth and quiet operation: Enjoy a comfortable ride with the VB1000's smooth and quiet operation.
- Safe and reliable: The VB1000 is equipped with advanced safety features to ensure a safe and reliable ride.
- Stylish design: The VB1000 complements your décor with its sleek and stylish design.

The VB1000 is the perfect solution for:

- Buildings with multiple floors
- People with mobility limitations
- Those who want the convenience of transporting heavy items between floors
- Offices
- The VB1000 isn't your average home lift. It's a screw-driven powerhouse designed to handle your toughest lifting tasks.
- Built for Strength and Stability:
 - Heavyweight Champion: Unlike traditional home elevators,

the VB1000 boasts a superior weight capacity, making it ideal for transporting groceries, furniture, and even bulk supplies between floors.

• Screw-Driven Advantage: The innovative screw-drive technology ensures a smooth, quiet, and reliable ride, free from the jerks and vibrations common in hydraulic elevators.

• Safe and Secure: Rest assured, the VB1000 prioritizes safety with advanced features like automatic shutoff and overload protection.

• Experience the VB1000 Difference:

• Effortless Convenience: No more struggling to carry heavy items up and down stairs. The VB1000 simplifies your daily routine.

• Increased Accessibility: The VB1000 makes your entire building accessible, perfect for those with mobility limitations.

• Space-Saving Design: The screw-driven technology allows for a compact design, maximizing your valuable living space.

•



DIFFERENT DOOR TYPES

- Aluminum impost door with glass;
- Automatic double swing door;
- Fire proof EI60;
- Fire proof EW60 – with various glass sizes; Aluminum.

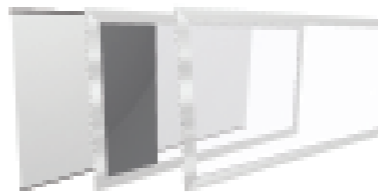

PANELS

Platform lift shaft can be assembled using multi-layered sandwich panels and laminated glass panels (30 mm). Aluminum profile.



FLOORING

Lift platform floor can be covered with different colour rubber or desired texture vinyl.

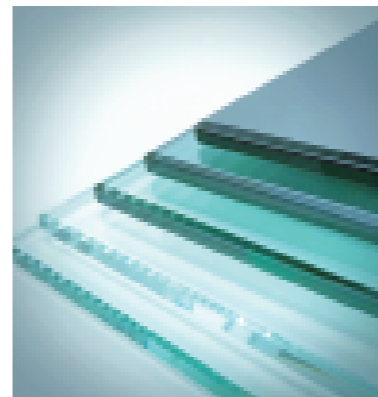

OPTIONS

- Additional floor indicators
- Automatic emergency lowering
- LED lighting
- Extra lighting options
- Voice announcer
- Floor indicator on the platform or landing
- Phone on the platform
- Auto dialer
- Access restriction options



COLOUR CUSTOMISATION

The whole lift can be painted in almost any colour to suit your taste and environment. You can choose from hundreds of RAL palette colours available.



8 PEOPLE



1000 KG

SUITABLE FOR:



VB1000

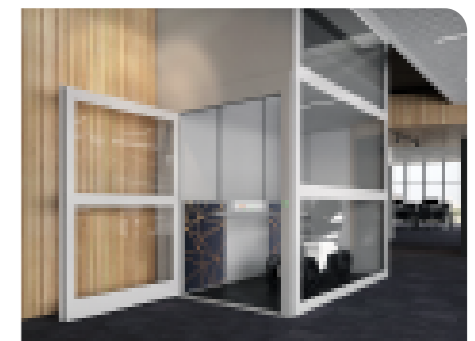

VB 1000: The Powerful and Smooth Screw-Driven Home Lift